

COLD.X

Comfort creator

Keeping your home cool by cooling and dehumidifying the air going to the dwelling. COLD.X is a direct expansion duct cooler (condenser – heater) intended to be used with a central MVHR unit or standalone fan.

Universal compatibility

COLD.X can be used with all MVHR units up to 600m³/h and AC outdoor units of appropriate capacity and possibility of external control.

Simple installation

Large 200mm air connections made of flexible and heat insulating material ensure simple installation and air-tight connections. Unit is universal in terms of airflow direction and can be installed with piping connections on the left or right side according to the air flow direction.

Robust design

Small and compact, painted metal housing with internal insulation and fixing points.

Blow free

A ventilation duct system is used to distribute cold air into rooms in precise amounts. Due to the lower noise level and low air speed, this method provides a very comfortable climate compared to conventional air conditioning systems.

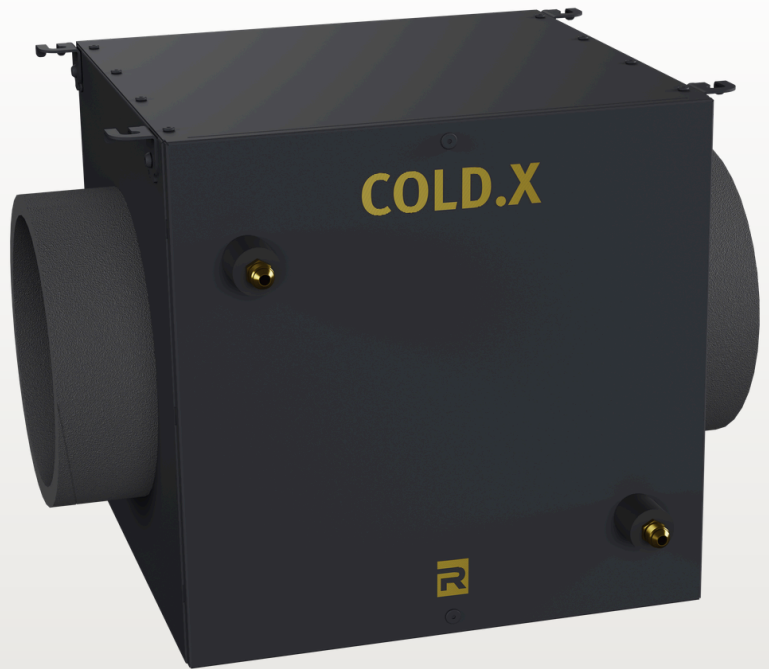

INSTANT COLD AIR

PERFECT INDOOR CLIMATE

BLOW FREE – HIGH COMFORT

COLD.X must be combined with the split AC outdoor unit of suitable capacity with possibility of external control and smart control system ensuring good and reliable working. The installation is generally the same as a typical split AC system. COLD.X can be a standalone solution for cooling or be used in combination with radiant cooling to achieve more sensible power. The low temperature of the supply air means that the distribution system must be insulated with closed cell insulation to prevent condensation formation on the outside of the ducts and elements of distribution system.

COLD.

Powerful cooling for your MVHR system.

Weight and dimensions (a x b x c)	17 kg (384x374x370mm)
Air connections diameter (D / d)	232/200mm
Piping connections	SAE1/4 & SAE3/8
Internal volume	0.7l
Condensate drain connections	DN32
Cooling power (600m ³ /h, IN 27°C/60%rh)*	3.2kW
Heating power (600m ³ /h, IN 18°C/30%rh)*	3.5kW
Min. airflow (depends on parameters of supply air)	≈150m ³ /h
Max. airflow	600m ³ /h
Working/test pressure (medium)	42/61bar

*Depends on the outdoor unit type.

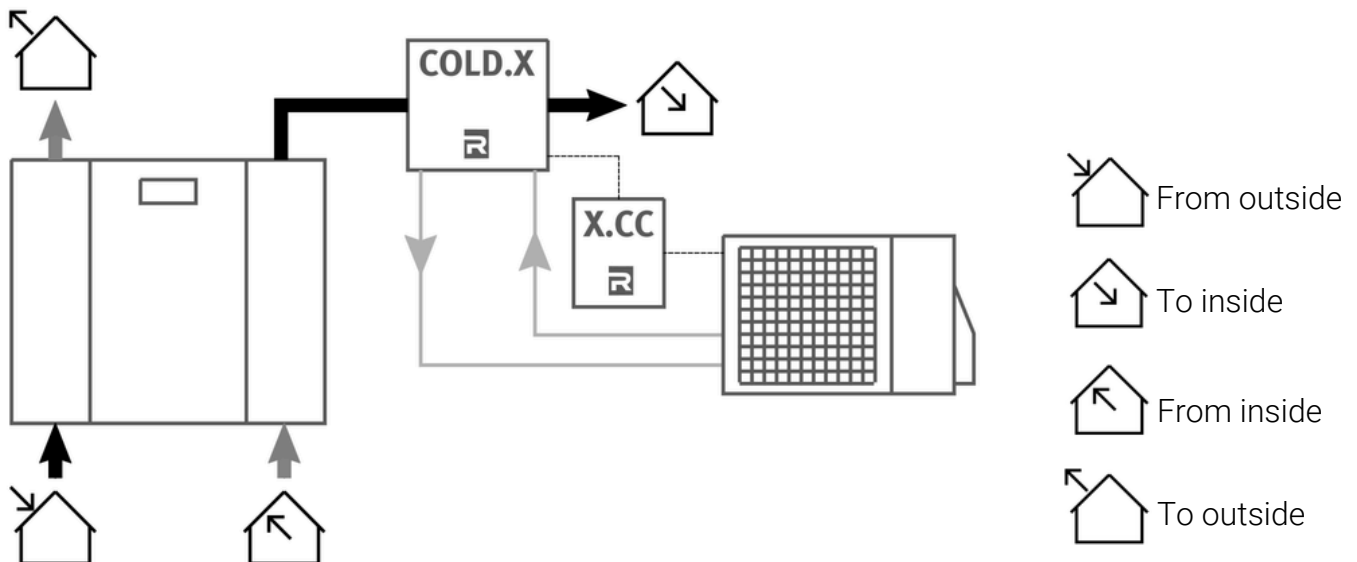
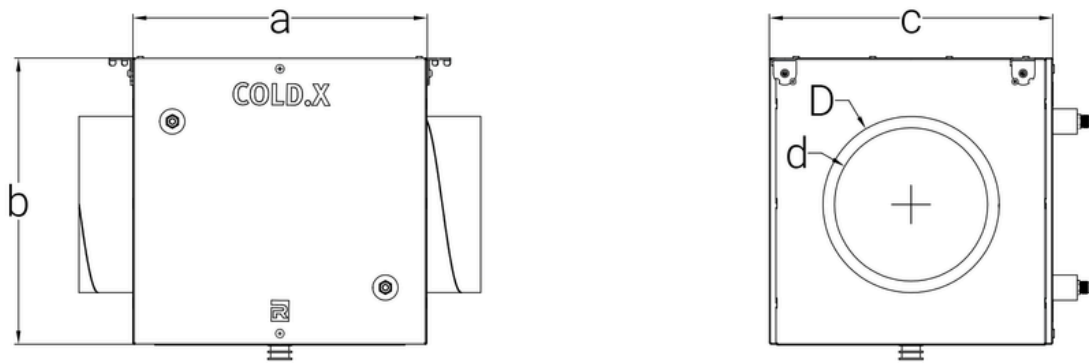

Principal schematics of COLD.X implementation.

SALE / INSTALLATION / SERVICE